

УДК 62-50:621.924...

Controlling turning contouring of shaped parts

Yuri Petrakov, John Maru Ezenduka

Igor Sikorsky Kyiv Polytechnic Institute, Kiev, Ukraine

Abstract. *The machining of contoured shaped surfaces of parts with a circular cross-section is executed on CNC lathes using control programs. All known CAM systems offer canned cycles for such surfaces. In most cases, it is recommended to use G71, G72 and G73 canned cycles for roughing contouring. The aim of the study is to analyze the cutting processes in roughing and finishing and to assess their influence on the surface quality of the part. A modeling technique is proposed, which is based on the use of an original application soft that allows simulating all machining cycles with fixing the results in the form of oscillograms of changes in the depth of cut. Comparative analysis of the results allows you to choose the most acceptable machining cycle for a specific profile of the contour of the part. The developed program also makes it possible to obtain the predicted accuracy of machining along the entire contour, which may arise as a result of technological heredity. In addition, the array of data on cutting depth obtained during the simulation, which is the main disturbance of the process, allows one to design the law of control of the cutting mode, for example, on the feed, which will lead to the stabilization of the cutting process.*

Keywords: *turning contouring, control program cycles, modeling.*

The turning of shaped surfaces of parts with a circular cross-section is performed on CNC lathes using control programs designed in any CAM system. All known CAM systems [1, 2] offer standard cycles for processing such surfaces. In most cases, it is recommended to use G71, G72 and G73 canned cycles for roughing contouring.

Cycle G71 is a longitudinal contouring cycle that cuts the rough allowance with longitudinal cutting passes. Such a cycle allows you to process a contour of almost any shape complexity; the number of passes in a cycle is calculated automatically through the parameter of the material cutoff value. The contour to be machined is programmed separately from the cycle, and is written as a normal tool path, which is convenient for editing. With each pass, the X-axis retraction is automatically calculated to reduce machine time.

G72 is a roughing cross contouring cycle in which machining is carried out in the X direction. This cycle is useful for machining profiled end faces and contour boring of holes. G73 is a roughing contouring cycle. The cycle is convenient to use for machining parts that have a uniform material allowance along the entire processing perimeter.

For a finishing cut, all of these cycles can be supplemented with a G70 cycle. It is noted [2] that the main disadvantage of all cycles is the impossibility of specifying a different cutting mode for each pass. In addition, no criteria are provided by which it is possible to preliminarily determine the best cycle in terms of both productivity and machining quality for a particular part.

The machining of shaped parts on a lathe is always characterized by quasi-stationarity, which is determined by the change in the material removal rate (MRR) when moving along the forming trajectory [3]. This makes it difficult to achieve the required accuracy, quality and acceptable performance. The assignment of the cutting mode, as a rule, is carried out intuitively for the most loaded area, and in this case, in all other areas, the tool and machine are significantly underloaded.

As the main disadvantage of the well-known and widely used CAM systems, it does not provide recommendations for the automatic setting of the cutting mode. The so-called "intelligent" systems that have appeared recently (iMachining SolidCAM, iMachining Siemens NX) are just beginning to conquer the market.

It is known that to stabilize the cutting process when machining such surfaces, it is recommended to use processing methods that are characterized by the information used for design control: a priori, flow (adaptive) or a posteriori [4]. Control by streaming or a posteriori information requires

the creation of special control systems [5], which complicates their use in practice. With control based on a priori information, programming with MRR stabilization is possible, however, the design of such control is possible only with a preliminary simulation of the machining.

In addition, it is necessary to select a process evaluation criterion that can be observed during the simulation. Since the main disturbance is the variable cutting depth, in the simulation program developed in the laboratory of virtual teaching aids of the Department of Mechanical Engineering [6], modules for calculating the cutting depth and advertising the results were built in.

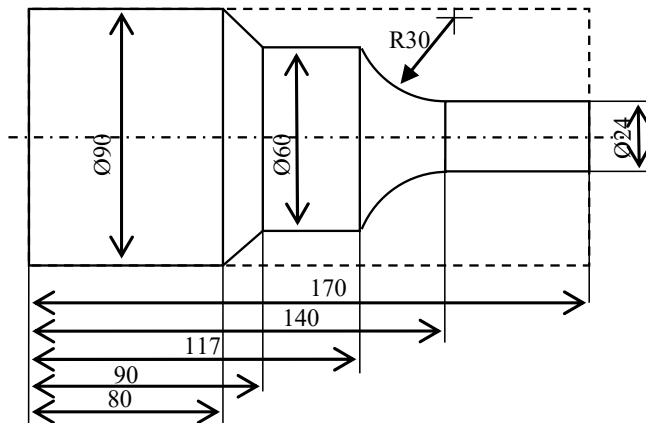

Fig. 1. Detail drawing

In order to check the effectiveness of the use of modeling to evaluate various methods for cutting off the rough stock and their effect on the stationarity of the finishing process and distortion of the contour of the part, the processing of the part was simulated, the drawing of which is shown in Fig. 1.

The same cutting conditions were used for all cycles. Roughing: depth 3 mm, feed 0.3 mm/rev, cutting speed 80 m/min; finishing pass: depth of cut 1 mm, feed 0.17 mm/rev, cutting speed 100 m/min. Other initial data of the technological machining system (TMS): machining in the chuck,

spindle stiffness 20000N/mm, caliper 18000 N/mm, part material – Steel45.

The simulation results of machining a part from a cylindrical workpiece using cycles G71, G72 and G73 are shown in Figures 2, 3 and 4 respectively.

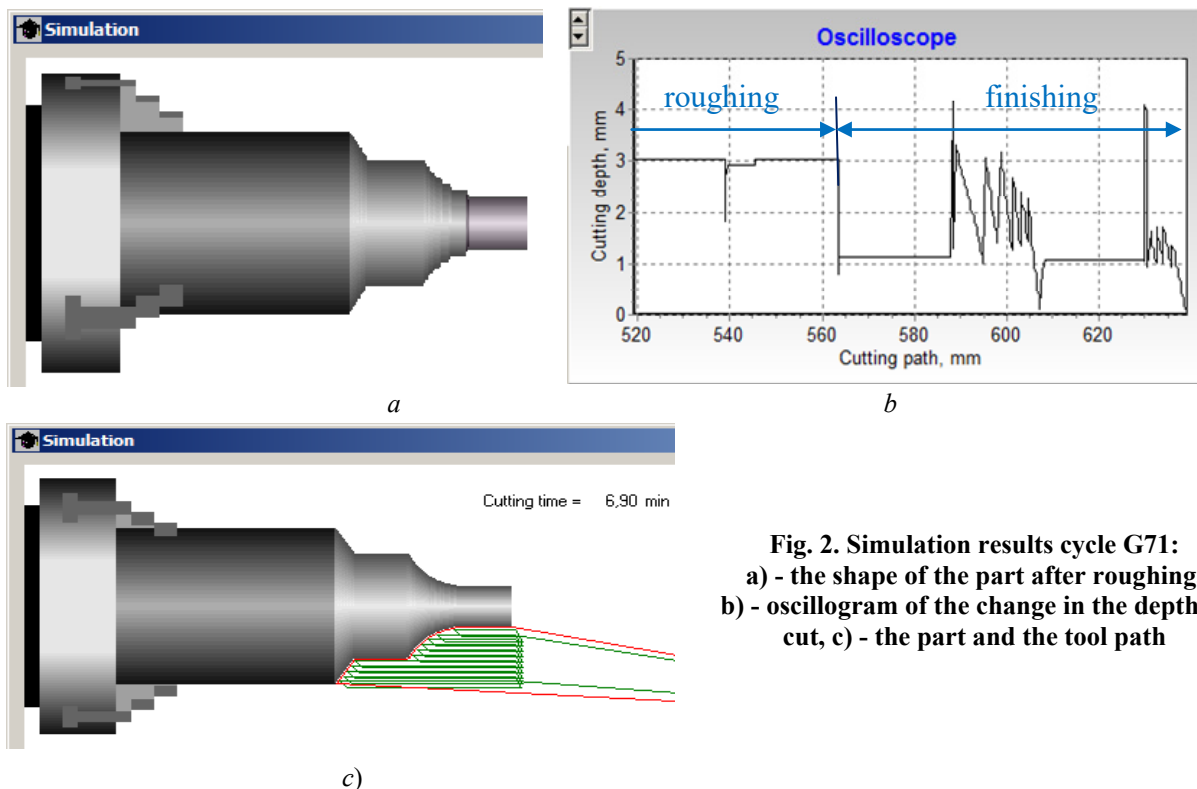
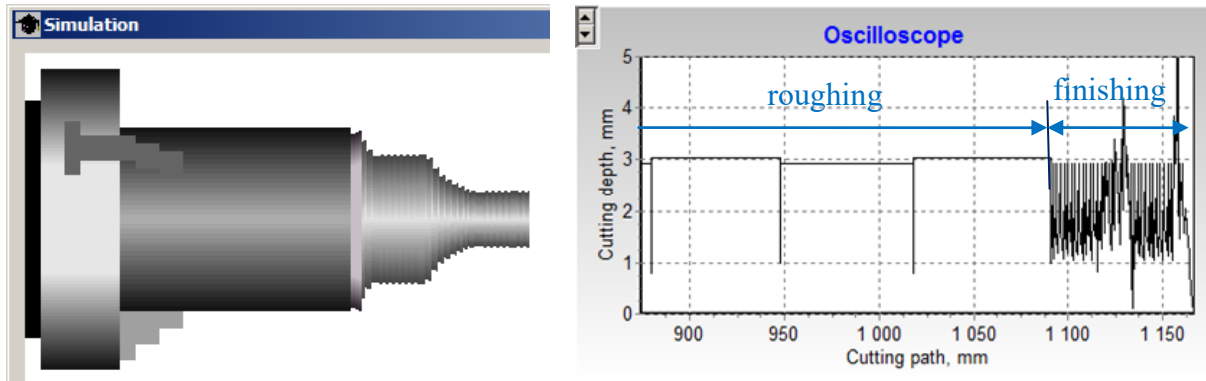
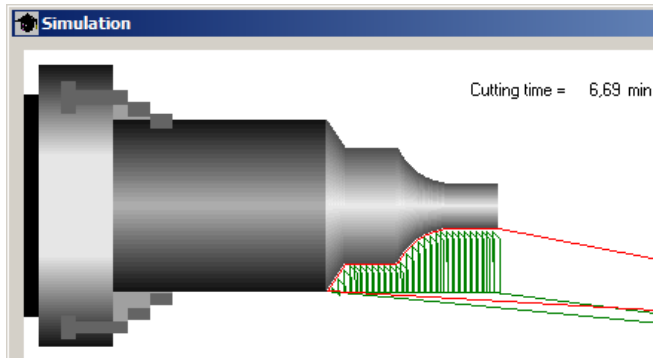

Fig. 2. Simulation results cycle G71:
a) - the shape of the part after roughing,
b) - oscillogram of the change in the depth of cut, c) - the part and the tool path



a)

b)



c)

Fig. 3. Simulation results cycle G72:
 a) - the shape of the part after roughing,
 b) - oscillogram of the change in the depth of cut,
 c) - the part and the tool path

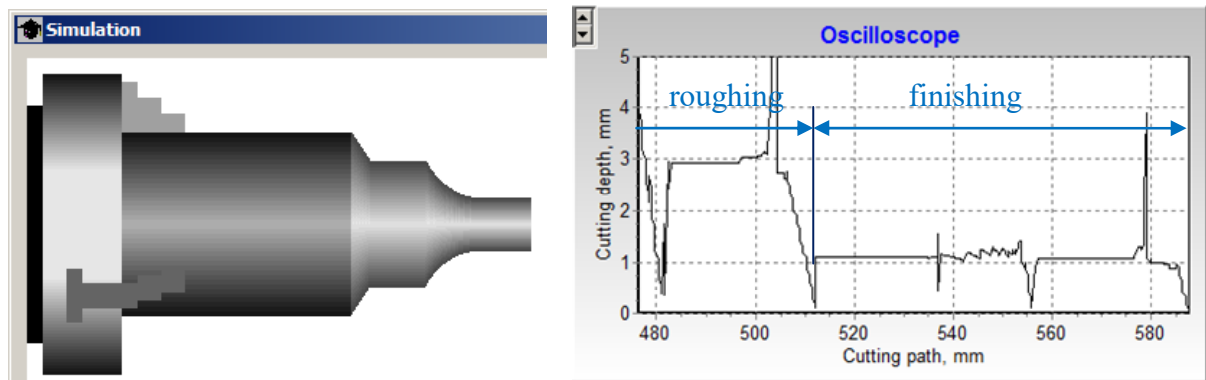

a)

b)

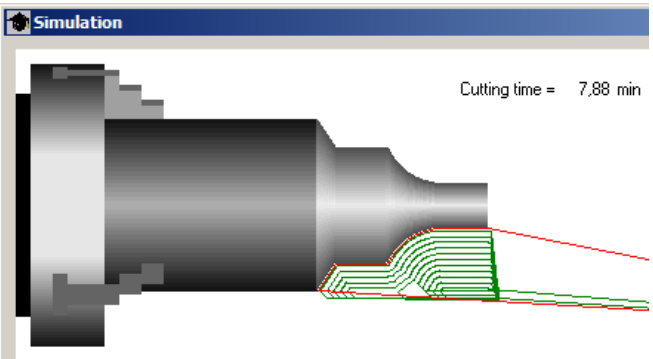

c)

Fig. 4. Simulation results cycle G73:
 a) - the shape of the part after roughing,
 b) - oscillogram of the change in the depth of cut,
 c) - the part and the tool path

Analysis of the obtained simulation results allows us to draw the following conclusions.

1. The shape of the workpiece after roughing in each machining cycle is very different and has a strong influence on the nature of the change in the depth of cut in the finishing pass. The cutting process on the finishing pass for all machining cycles is characterized by significant non-stationarity, which will affect the shape of the contour of the machined part due to technological heredity.

2. The developed methodology and application program makes it possible to assess the change in the main indicator of the cutting process - MRR and to design the process control at the finishing pass, for example, by changing the feed, in order to stabilize it. Using the "Look Ahead" option available on a modern CNC machine, for example, from HAAS, will make this control possible in practice.

References

1. Steven S. Saliterman CNC Lathe Programming. University of Minnesota // https://saliterman.umn.edu/sites/saliterman.dl.umn.edu/files/general/cnc_lathe_programming.pdf
2. Funuc Series Oi-model D. Для системи токарного станка // <https://rustan.ru/sites/default/files/instructions/Fanuc%200i.pdf>
3. D. Huo, K. Cheng, F. Wardle Machining Dynamics: fundamentals, applications and practices / Springer-Verlag London Limited, 2009, 328p.
4. Петраков Ю.В. Розвиток САМ-систем автоматизованого програмування верстатів з ЧПК: Монографія. – Київ, Січкап, 2011. – 220 с.
5. Петраков Ю.В., Мацкивський А.С. Моделирование системы адаптивного управления на токарном станке с ЧПУ // 36. наукових праць «Надійність інструменту та оптимізація технологічних систем Випуск 36 Донбаська державна машинобудівна академія, Краматорськ, 2016, с.12-17.
6. Петраков Ю.В. Методи управління процесами різання // Вісник ЖДТУ № 2 (80), Житомир, 2017. – с. 124-134.

Управління токарною контурною обробкою фасонних деталей

Петраков Ю.В.; Езендука Джон Мару

***Анотація.** Обробка контурних фасонних поверхонь деталей, що мають круглий поперечний переріз, виконується на токарних верстатах з ЧПУ по керуючим програмами. Всі відомі САМ-системи пропонують стандартні цикли для обробки таких поверхонь. У більшості випадків рекомендується застосовувати стандартні цикли чорнової контурної обробки G71, G72 і G73. Метою дослідження є аналіз процесів різання в чорновій і фінішній обробки і оцінка їх впливу на якість поверхні деталі. Порівняльний аналіз результатів дозволяє вибрати найбільш прийнятний цикл обробки для конкретного профілю контуру деталі. Розроблена програма також дозволяє отримати прогнозовану точність обробки по всьому контуру, яка може виникнути в результаті технологічної спадковості. Крім того, отриманий під час моделювання масив даних по глибині різання, який є головним об'єктом процесу, дозволяє спроектувати закон управління режимом, наприклад, з подачі, які призведе до стабілізації процесу різання.*

***Ключові слова:** токарна контурна обробка, цикли керуючої програми, моделювання.*